



VERSATILE, EFFICIENT, COST EFFECTIVE

INSURAL*

INSULATING REFRACTORY MATERIAL FOR ALUMINIUM AND ZINC

Low wettability / easy to clean

High insulating effect / energy saving

Good mechanical strength

Easy maintenance

Low costs



INSURAL insulating refractory material

for high quality demand in casting processes

Refractory insulating material

The handling of molten metals requires the use of refractory materials, which protect "man and machine" from the high temperatures of these metals. They also ensure the quality of the melt is maintained or even improved; and keep the machines in good condition, enabling the foundryman to work in a clean and efficient way over an extended period of time.

These refractory materials must be adapted to fulfil the various requirements of the metals. The INSURAL name stands for a group of materials which have proven to be effective especially for aluminium and zinc, for several years now. These materials can also be used for other molten metals, provided the temperature lies below 1000 °C.

The right dimension for every application

INSURAL refractories are available both as a paste and as pre-formed shapes. The INSURAL pastes are highly insulating and can be used, for example, not only as adhesives but also for the repair of cracks and the sealing of joints etc. In the production of ready-to-use shapes, several INSURAL material types are used with differing degrees of strength and insulating properties. Examples of use are launders, nozzles and pre-fabricated pouring ladles for 40-2000 kg of aluminium.

Made to measure shapes

Small shapes with very accurate dimensions can also be produced, which are suitable as permanent feeders in die-casting (e.g. pistons for combustion engines) as gate linings for wheel production and many other applications. The INSURAL 50 refractory system is mainly used for these smaller shapes. It is a paste which is poured, so very complicated geometrical shapes can be manufactured economically.

All INSURAL materials are free from hazardous materials as defined in the "Gefahrstoffverordnung" (German regulations governing the handling of hazardous goods).

Made to measure and cost effective shapes



Application for metal transport

INSURAL 140 and INSURAL 180 refractories are typically used for larger shapes where strength is more important than insulating properties. This is often the case when relatively large quantities of metal react only slowly to the slightly lower insulation, or when the contact time between metal and INSURAL is short. Typical applications are transport ladles, pouring basins, transfer launders or filling funnels.

INSURAL 140 for larger shapes and higher strength



The drawings on the right show a filter funnel used to pour molten metal into low pressure or bale-out furnaces. In the upper container, there is a SIVEX* FC filter, which cleans the melt and transfers it turbulence free.

INSURAL 50 insulating sleeves are highly suitable for use as permanent feeders in die-casting. Dependent on the casting they can be used from 500 to several thousand casting operations.

Applications of INSURAL shapes are extremely varied, which is why only the most typical ones can be described in this brochure. Wherever you may need an insulating, non wetting product, please get in touch with us – together we will find a solution to your casting problem.

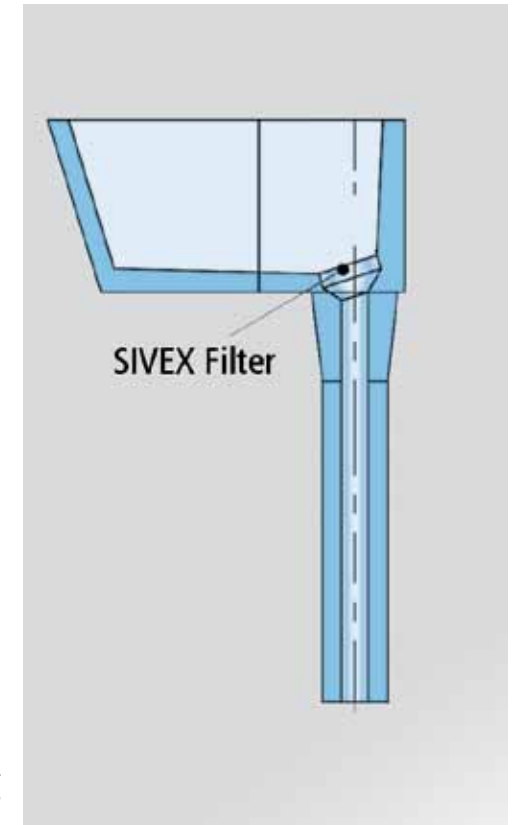

Filter funnel used to pour molten metal into low pressure or bale-out furnaces

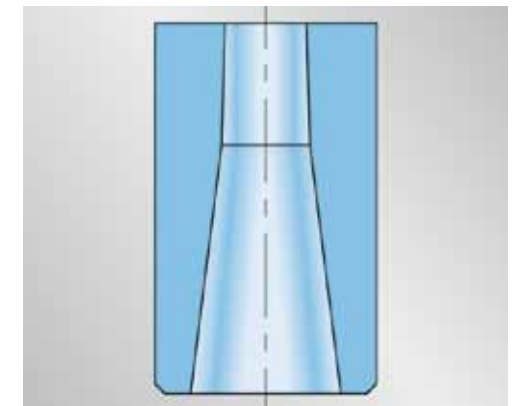

INSURAL 50 insulating sleeves



INSURAL applications

for low pressure die casting

Low pressure casting is the most common casting process for the production of aluminium wheel rims. The connection between riser tube pipe and die is frequently formed by the upper bush and the intermediate bush, which are made from steel. For the casting process, these must be heated to a high temperature.

Because of its highly insulating properties, when INSURAL refractories are used there is no need for further heating.

The upper bush is produced in very many different dimensions and is additionally wrapped in mineral fibre paper, which on the one hand further increases

the insulating effect and on the other hand enables a good fit in the steel casing. The intermediate bush is also available in many different dimensions and versions. Special sizes are available.

Advantages:

- No need for heating: Gas savings of up to 25m³/machine per day
- No rising heat, more die chill
- Higher productivity due to shorter cycles
- Better working conditions due to less heat, less noise, cleaner air

Example of upper bush for wheel production

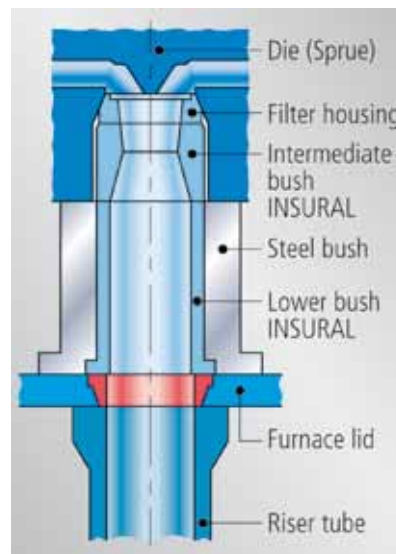

INSURAL dosing furnace applications

INSURAL shapes are also well suited for use in dosing furnace applications where they are a low-cost alternative to clay-graphite parts. Typical applications include the upper filling cone, riser tube and launder.

The upper filling cone, flow-optimized in accordance with Nielsen principles, is especially of note – it guarantees the turbulence-free filling of the furnace, thereby reducing oxide inclusions in the melt.

INSURAL transport ladle applications

Pre-fabricated INSURAL shapes for transport ladles are already in use for metal quantities from approximately 40 kg to more than 2000 kg. Their installation in existing steel shells is swift and simple.

The newly lined ladle is ready for use once more after a brief period, as a time-consuming drying operation is not necessary.



INSURAL shapes for dosing furnace – wear resistant and long service life



INSURAL lining for transport ladles – quick and easy installation

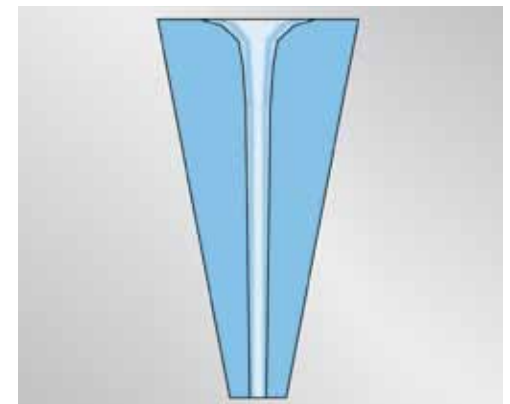

Flow optimised filling cone

Applications for tilt casting

INSURAL pouring basin

The tilt casting process needs a pouring basin to fill the mould. These are normally made from steel and very often not lined, but are sometimes coated or lined with standard refractory material. Often these steel pouring basins are continuously heated by gas to avoid heat loss. A typical lifetime for a steel basin is approx. 6000 castings. Where two castings are poured simultaneously pouring may not be perfect and one casting may receive slightly more metal than the other. This will result in one casting being short poured; this causing shrinkage porosity due to reduced feeding and resulting in rejected castings.

Also, after pouring, a skull often remains in the ladle. This skull is mainly aluminium oxide and results in metal loss.

When lining a pouring basin with an INSURAL insert the following advantages are achieved:

- Less heat loss
- A consistent pouring temperature
- More even filling of the two cavities
- Smoother, less turbulent flow
- Thinner skull remaining in the ladle
- Lower reject rate of castings

The outcome should be an improved yield and reduced reject rate of castings. Several designs of pouring basin were reviewed by flow simulation to optimise ladle shape before manufacture.

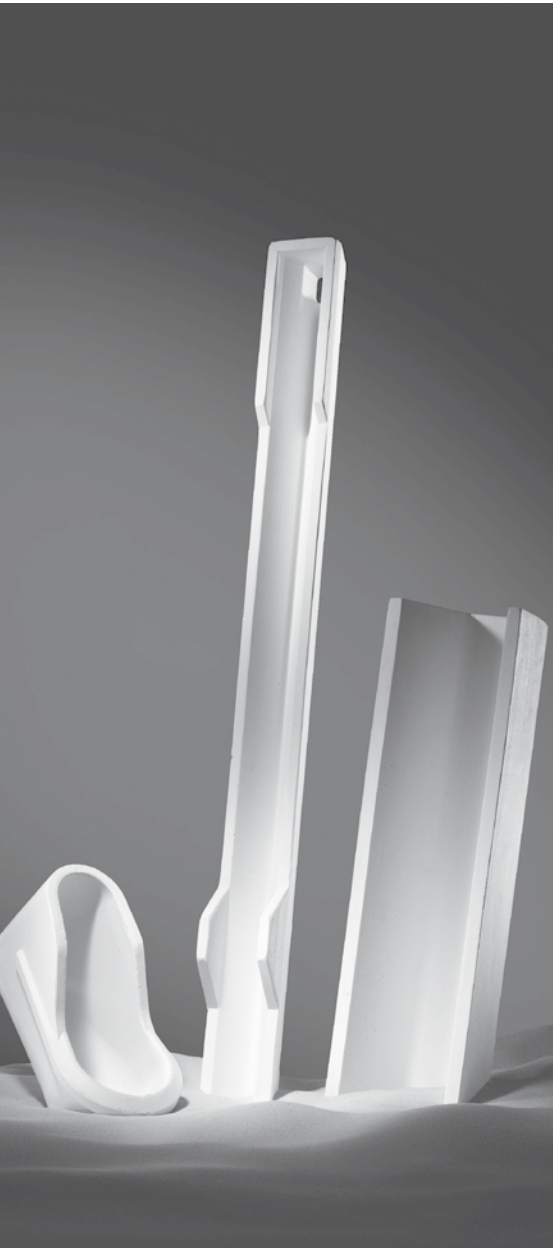

Pouring basin to fill the mould



Pouring basin in flow simulation

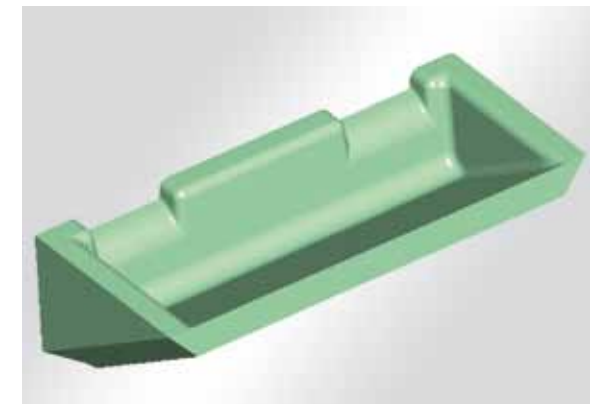

Technical data

Example: Automotive Foundry, casting type brake calipers and assemblies

- 300% increase in lifetime
 - Scrap rate reduced from 8% to 5%
 - Cost savings
 - Casting scrap savings \$ 198.000
 - Machining scrap savings \$ 36.000
 - Tipper ladle savings \$ 27.000
 - Skull weight savings \$ 70.000
 - Dross loss savings \$ 7.000
- Total annual savings **\$ 338.000**

Properties		INSURAL 50	INSURAL 140	INSURAL 170	INSURAL 180
Density	g/cm ³	~ 1.1	~ 1.4	~ 1.7	~ 1.8
Strength	MPa (20 °C)	2	3	5	7
	MPa (750 °C)	3	5	6	11
Expansion coefficient	K ⁻¹	4.5* 10 ⁻⁶	3.9* 10 ⁻⁶	0.9* 10 ⁻⁶	1.25* 10 ⁻⁶
Open porosity	%	70	42	20	21
Hygroscopicity	% (20 °C, 65% RH)	0.8	0.6	0.1	0.1
	% (20 °C, 90% RH)	2.5	2.0	0.6	0.6
Heat conductivity	W/mK	0.4 (600 °C)	0.47 (745 °C)	0.85 (745 °C)	0.94 (745 °C)
Heat capacity	J/kgK	950	1001	1050	1100

		Sealant / Adhesive		Adhesive
Properties		INSURAL 700	INSURAL 800	INSURAL 7480
Density (wet)	g/cm ³	1.1	1.1	1.4
Density (dry)	g/cm ³	0.6	0.8	0.9
Transverse strength	N/mm ²	1.5	3.0	-
Heat conductivity	W/mK	0.08	0.1	0.1
Shrinkage	%	0.05	0.05	-
Max. appl. temperature	°C	1100	1100	1100

Foseco International Limited
Drayton Manor Business Park,
Tamworth, Staffordshire,
England B78 3TL
Phone: +44 (0)1827 262021
Fax: +44 (0)1827 283725
www.Foseco.com
Please contact your local Foseco team

*FOSECO, the Logo INSURAL and SIVEX are trade marks of the Vesuvius Group, registered in certain countries, used under licence. All rights reserved. No part of this publication may be reproduced, stored in a retrieval system of any nature or transmitted in any form or by any means, including photocopying and recording, without the written permission of the copyright holder or as expressly permitted by law. Applications for permission shall be made to the publisher at the address mentioned.
Warning: The doing of an unauthorised act in relation to a copyright work may result in both a civil claim for damages and criminal prosecution. All statement, information and data contained herein are published as a guide and although believed to be accurate and reliable (having regard to the manufacturer's practical experience) neither the manufacturer, licensor, seller nor publisher represents nor warrants, expressly or impliedly: (1) their accuracy/reliability, (2) that the use of the product(s) will not infringe third party rights, (3) that no further safety measures are required to meet local legislation. The seller is not authorised to make representations nor contract on behalf of the manufacturer/licensor. All sales by the manufacturer/seller are based on their respective conditions of sale available on request.
© Foseco International Limited 05/11.

